

Microprocessor-Controlled Pulsed NQR Spectrometer for Automatic Acquisition of Zeeman Perturbed Nuclear Quadrupole Spin Echo Envelope Modulations (ZSEEM)*

Narsimha Reddy, Arun Bhavsar, and P. T. Narasimhan

Department of Chemistry, Indian Institute of Technology, Kanpur 208 016, India

Z. Naturforsch. **41 a**, 449–452 (1986); revised version received November 5, 1985

A simple microprocessor-controlled pulsed NQR spectrometer system has been developed with the capability to acquire Zeeman perturbed spin echo envelope modulations (ZSEEM). The CPU of the system is based on the Intel Corporation 8085A microprocessor. The performance of the spectrometer is illustrated with the presentation of ZSEEM spectra of NaClO_3 and KClO_3 .

Introduction

Nuclear quadrupole interaction is characterized by two parameters namely, (i) the quadrupole coupling constant ($e^2 q Q h^{-1}$) and (ii) the asymmetry parameter (η) of the electric field gradient (EFG) tensor. For the case of nuclei with spin $I = 3/2$, there exists, in the absence of a magnetic field, a single transition frequency (ν_Q) in the pure NQR spectrum [1]. Hence it is not possible to obtain the two parameters $e^2 q Q h^{-1}$ and η from pure NQR without application of an external magnetic field. Zeeman NQR has been utilized to obtain these parameters in both single crystal [2] and polycrystalline specimens [3–5]. The higher sensitivity and convenience of employing long-term signal averaging in pulsed NQR spectrometers are expected to facilitate the evaluation of η from Zeeman NQR studies of polycrystalline samples. The Zeeman perturbed spin echo envelope modulation (ZSEEM) patterns contain the information on η [6]. Due to the insensitivity of the spin echo signal to static inhomogeneities, splittings will be observed as echo envelope modulations even when they are obscured in the steady-state experiments. We have therefore explored the possibility of determining η for spin $I = 3/2$ nuclei from ZSEEM patterns. Automation of pulsed NQR systems utilizing minicomputers [7–9] has been discussed in the litera-

ture. Compared to minicomputer-based systems, microprocessor-based systems are relatively inexpensive. Hence we have automated our pulsed NQR spectrometer [10] using a microprocessor system.

Experimental

A low cost Intel 8085A-based eight-bit microprocessor system (Microfriend-I) manufactured by M/s Dynalog Micro-Systems, Bombay, is the control system in the present spectrometer. The required spin echo pulse sequence generated by the microprocessor system is used to gate the rf signal from a signal generator (Model 8640 B, Hewlett-Packard, USA). The rf gating scheme used was described earlier [10]. The gated rf pulses are amplified using a low-noise, tuned power amplifier [10] and coupled to the sample coil through an impedance matching and tuning network. The NQR signal induced in the sample coil is first amplified using a 3N-200 FET based tuned preamplifier and subsequently amplified and detected by a broadband receiver (Model 625, Matec, USA). The NQR signal information available at the output of the receiver can either be presented on an oscilloscope or be processed further using a signal analyzer (Model SM-2100B, Iwatsu Electric Co. Ltd., Tokyo, Japan). In the case of a two-pulse sequence with an interval τ , a spin echo signal is generated and a boxcar averager (Model CW-1, Princeton Applied Research, USA) is used to sample the echo maximum amplitude at 2τ after the first pulse.

The 8085A microprocessor chip contains six general purpose eight-bit registers (namely, B, C, D,

* Presented at the VIIIth International Symposium on Nuclear Quadrupole Resonance Spectroscopy, Darmstadt, July 22–26, 1985.

Reprint requests to Prof. P. T. Narasimhan, Department of Chemistry, Indian Institute of Technology, Kanpur 208 016, Indien.

0340-4811 / 86 / 0100-0449 \$ 01.30/0. – Please order a reprint rather than making your own copy.



Dieses Werk wurde im Jahr 2013 vom Verlag Zeitschrift für Naturforschung in Zusammenarbeit mit der Max-Planck-Gesellschaft zur Förderung der Wissenschaften e.V. digitalisiert und unter folgender Lizenz veröffentlicht: Creative Commons Namensnennung-Keine Bearbeitung 3.0 Deutschland Lizenz.

Zum 01.01.2015 ist eine Anpassung der Lizenzbedingungen (Entfall der Creative Commons Lizenzbedingung „Keine Bearbeitung“) beabsichtigt, um eine Nachnutzung auch im Rahmen zukünftiger wissenschaftlicher Nutzungsformen zu ermöglichen.

This work has been digitalized and published in 2013 by Verlag Zeitschrift für Naturforschung in cooperation with the Max Planck Society for the Advancement of Science under a Creative Commons Attribution-NoDerivs 3.0 Germany License.

On 01.01.2015 it is planned to change the License Conditions (the removal of the Creative Commons License condition "no derivative works"). This is to allow reuse in the area of future scientific usage.

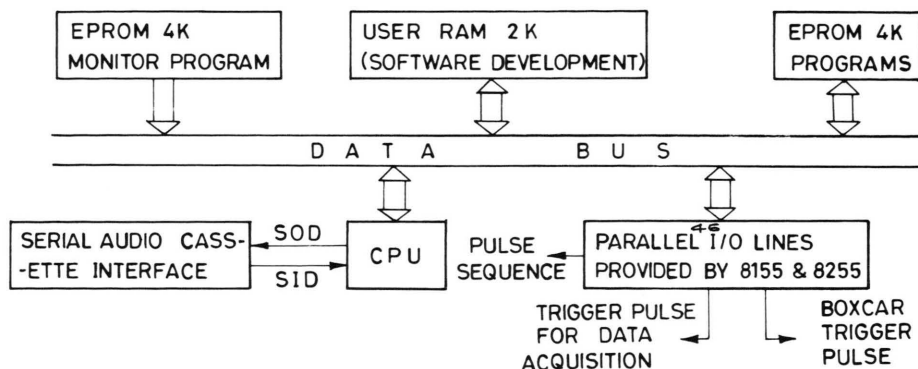

Fig. 1. Functional block diagram of the microprocessor system (Microfriend-I) showing the common communication path between the various components through the data bus.

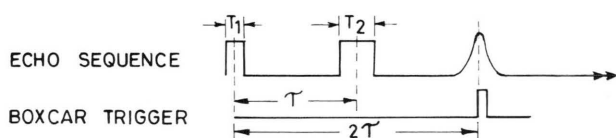

Fig. 2. Echo pulse sequence along with the boxcar trigger pulse.

E, H and L) for data storage and data transfer, and an eight-bit accumulator (Register A) for performing arithmetic and logic operations. The functional block diagram of the microprocessor system is shown in Figure 1. The processor of this system utilizes a 6.144 MHz crystal, the clock rate being 3.072 MHz. The system has a 2 K RAM which is useful for developing software programs and a 4K EPROM for storing the programs. It also has a serial audio cassette interface for bulk storage. There is an on-board EPROM programmer to load software programs into EPROM. Facility also exists for expanding the memory up to 32 K of RAM or EPROM (or any mix of these two memories).

A programmable peripheral interface (PPI) 8255A-5 is used for outputting the pulse sequences, the trigger pulse for the boxcar averager (read pulse) and also the trigger pulse for the initiation of data acquisition. The PPI has three eight-bit I/O (input/output) ports, A, B and C. Three bits of the port A, bits 6, 7, and 8, are utilized to output (through BNC connectors) the echo sequence, the boxcar trigger pulse, and the trigger pulse for data acquisition, respectively.

We have written a suitable program which enables the microprocessor to generate a two-pulse

sequence with τ values automatically incremented and the corresponding echo maximum amplitude acquired by the signal analyzer. In the initiation part of the program desired numbers are stored for various parameters of the pulse sequence, namely, the pulse widths of first and second pulses (t_1 and t_2) and pulse separation τ (see Fig. 2), and through appropriate delay routines these numbers are translated into time intervals. To achieve lowest possible values for pulse widths (t_1 and t_2) through appropriate delay routines it was necessary to store the corresponding numbers in the 8085A registers (B, D and C for t_1 , t_2 and τ , respectively) rather than storing in the memory because the data transfer is faster between various registers and the accumulator than the transfer between memory and accumulator. By these registers and corresponding delay routines it was possible to obtain a minimum value of 10 μsec for pulse widths (t_1 and t_2), which could be incremented in steps of 4 μsec . The software is written in such a way that the pulse sequence is repeated a preset number of times for each value of τ in order to enable the boxcar averager to give a stable voltage output corresponding to the echo maximum at 2τ . The number of times that the pulse sequence has to be repeated is determined by the setting of the time constant of the boxcar integrator, which in turn is optimized for the best S/N ratio. After repeating the sequence a given number of times the program increments the contents of C register and generates the sequence with an increased value of τ , and the process continues till the maximum desired value of τ is reached. The program also generates and outputs

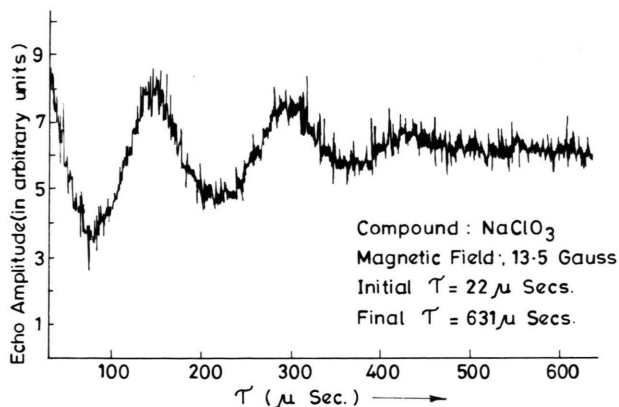

Fig. 3. Experimental ^{35}Cl ZSEEM pattern in NaClO_3 ($\omega_0 = 29.902$ MHz) at $\cong 298$ K.

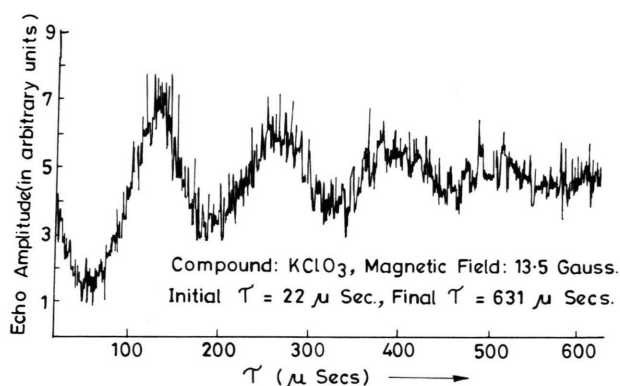

Fig. 4. Experimental ^{35}Cl ZSEEM pattern in KClO_3 ($\omega_0 = 28.0896$ MHz) at $\cong 298$ K.

through another BNC connector, a trigger pulse at 2τ (from the first pulse of the echo sequence) to open the boxcar gate and to sample the echo maximum. Apart from generating an echo sequence and boxcar trigger pulse, the program also generates another pulse in a third BNC connector which initiates the data acquisition into the memory of the signal analyzer. The program can be run in two modes, namely, (i) set mode, and (ii) measure mode. In the "set mode" the separation between the pulse is not incremented and also the trigger pulse to the signal analyzer is not generated, but the presentation of the signal can be made on an oscilloscope. In the "measure mode" the data acquisition by the signal analyzer is initiated for a given value of τ and the data are acquired with pulse separation

incremented. The spectrometer is operated in the "measure mode" only when the data are to be acquired after adjusting all the experimental parameters in the "set mode". Transfer from "set mode" to "measure mode" is achieved by the interrupt facility available in the microprocessor system. Program listings and flow charts are available upon request from the authors.

Results

The microprocessor-controlled pulsed NQR spectrometer described above has been employed to investigate ^{35}Cl ZSEEM patterns in polycrystalline specimens of the model compounds NaClO_3 and KClO_3 at $\cong 298$ K. The external Zeeman field has been oriented parallel to the rf field. A home-made low noise tuned power amplifier [10], which gives an rf power of $\cong 500$ Watts has been utilized in recording the ZSEEM spectra. The pulse separation τ has been altered from an initial value of 22 μsec to a final value of 631 μsec in steps of 5 μsec . For each setting of τ sufficient time was given to effect the single point boxcar averaging. The time taken for a complete ZSEEM spectrum is typically 40 minutes. As described earlier, the data from the boxcar output are acquired into the memory of the signal analyzer and are transferred to an in-built mini-floppy disk of the signal analyzer for permanent storage. The ZSEEM spectrum stored in the floppy can be taken, when desired, on to an X-Y recorder through "pen out" of the signal analyzer. Compared to the earlier unautomated system the microprocessor-based spectrometer system offers complete ease to the operator. The ZSEEM patterns for the ^{35}Cl nuclei in NaClO_3 and KClO_3 are shown in Figs. 3 and 4. These patterns agree with the experimental ZSEEM patterns reported earlier [6] for the case of $\eta = 0$.

In addition to generating the two-pulse sequence required for ZSEEM, the microprocessor system is capable of generating several other pulse sequences of use in magnetic resonance spectroscopy. For example pulse sequences required for the measurement of various relaxation times, multiple pulse sequences required for line narrowing studies in magnetic resonance, etc. can be generated by suitable software. This has resulted in a considerable reduction of the hardware. Further details of our

microprocessor-controlled NQR spectrometer system and newer results on ZSEEM spectra will be published elsewhere.

This work was made possible by financial assistance received from the Department of Atomic Energy, Government of India.

- [1] T. P. Das and E. L. Hahn, *Nuclear Quadrupole Resonance Spectroscopy*, Academic Press, London 1958.
- [2] C. Dean, *Phys. Rev.* **96**, 1953 (1954).
- [3] Y. Morino and M. Toyama, *J. Chem. Phys.* **35**, 1289 (1961).
- [4] K. V. Raman and P. T. Narasimhan, *Pure Appl. Chem.* **32**, 271 (1972).
- [5] V. Harihara Subramanian and P. T. Narasimhan, *J. Molec. Struct.* **58**, 193 (1980) and references therein.
- [6] R. Ramachandran and P. T. Narasimhan, *Mol. Phys.* **48**, 267 (1983).
- [7] D. Giezendanner, R. Lenk, and G. Litzistorf, *J. Phys. E: Sci. Instrum.* **8**, 8 (1975).
- [8] D. Giezendanner, S. Sengupta, and G. Litzistorf, *J. Mol. Struct.* **58**, 519 (1980).
- [9] M. Gourdjji and A. Pèneau, *J. Mol. Struct.* **83**, 361 (1982).
- [10] R. Ramachandran and P. T. Narasimhan, *J. Phys. E: Sci. Instrum.* **16**, 643 (1983).